

| REV. | DESCRIPTION | DATE | APPROVED |
|------|-------------|------|----------|
| | | | |

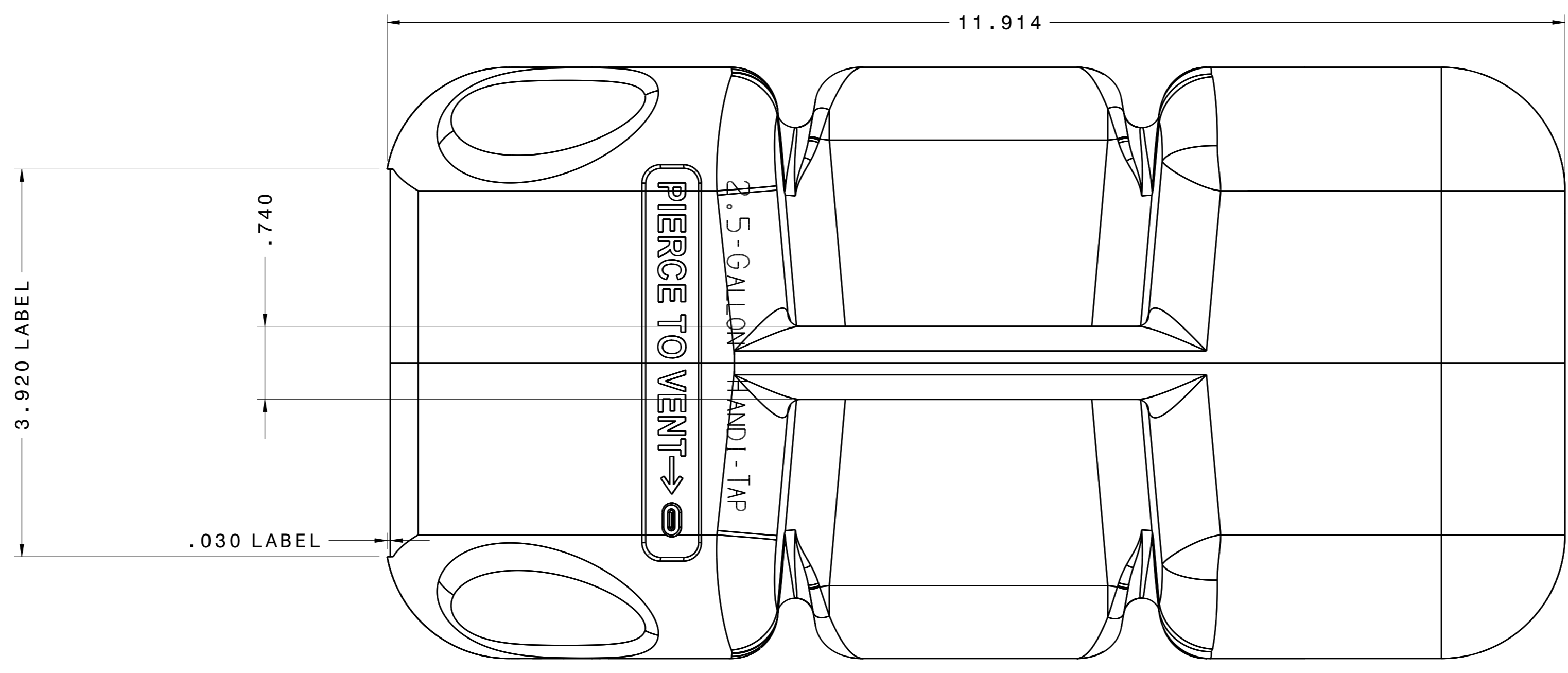

Top view
Scale: 1:1

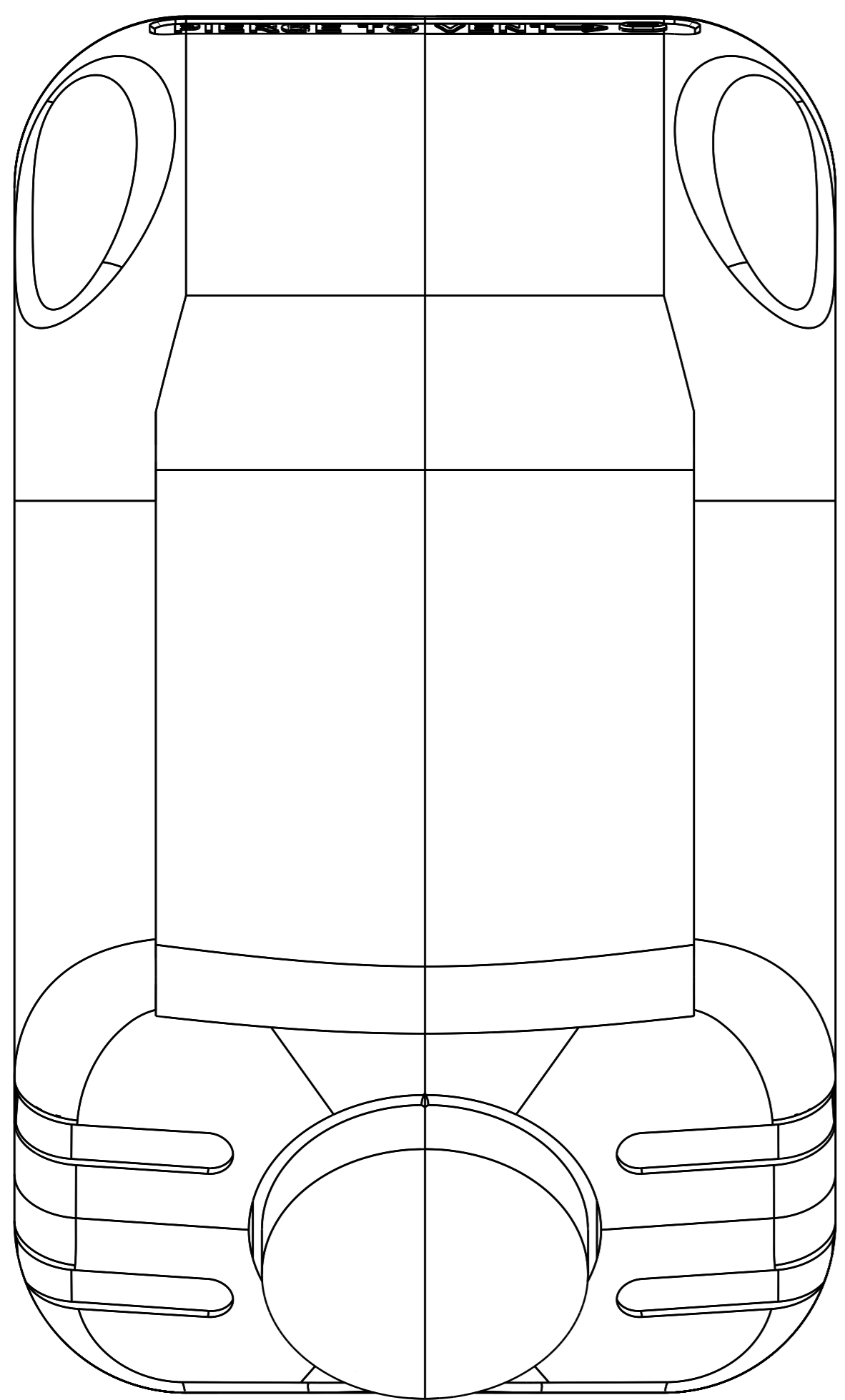

Left view
Scale: 1:1

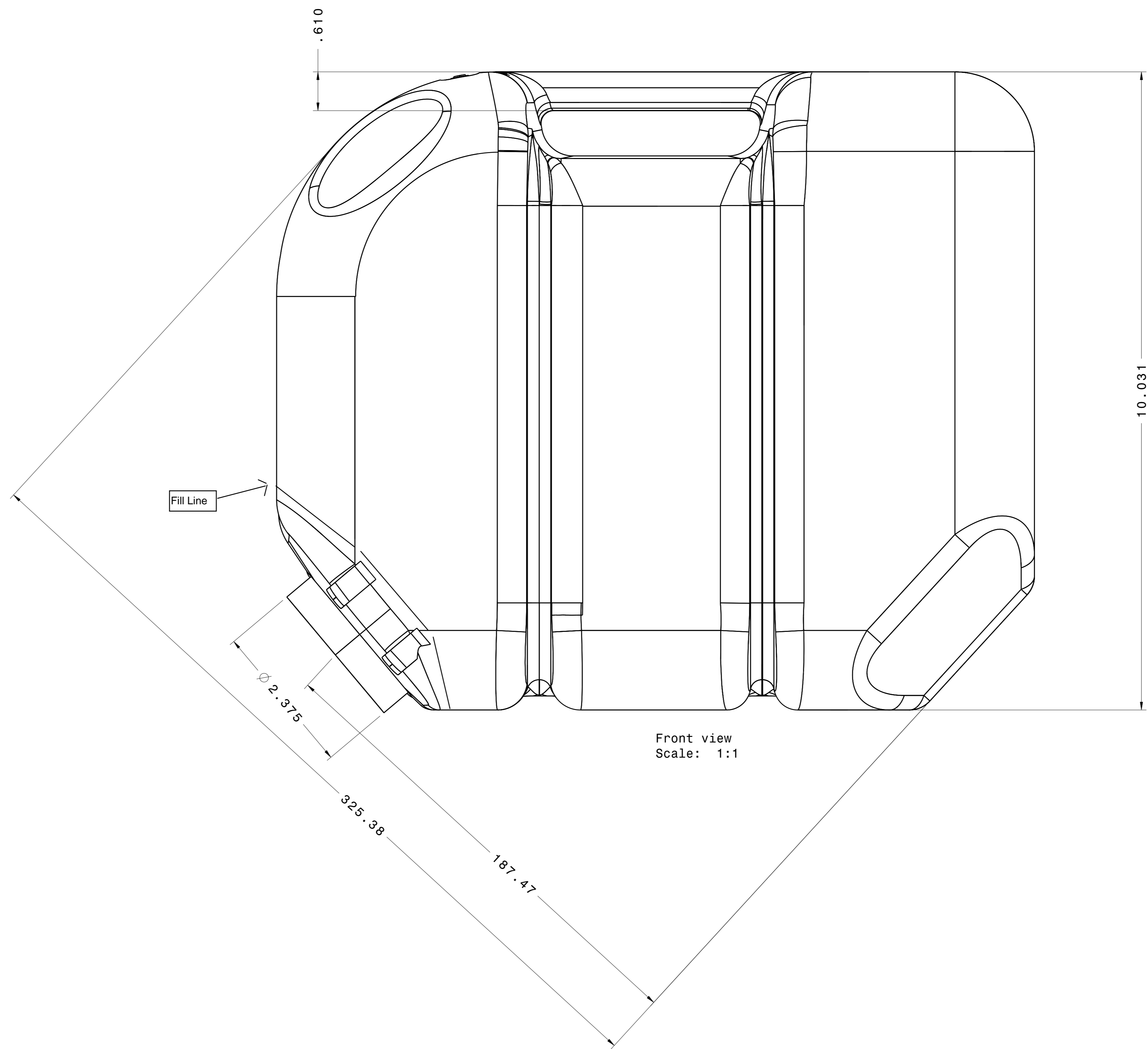

Front view
Scale: 1:1

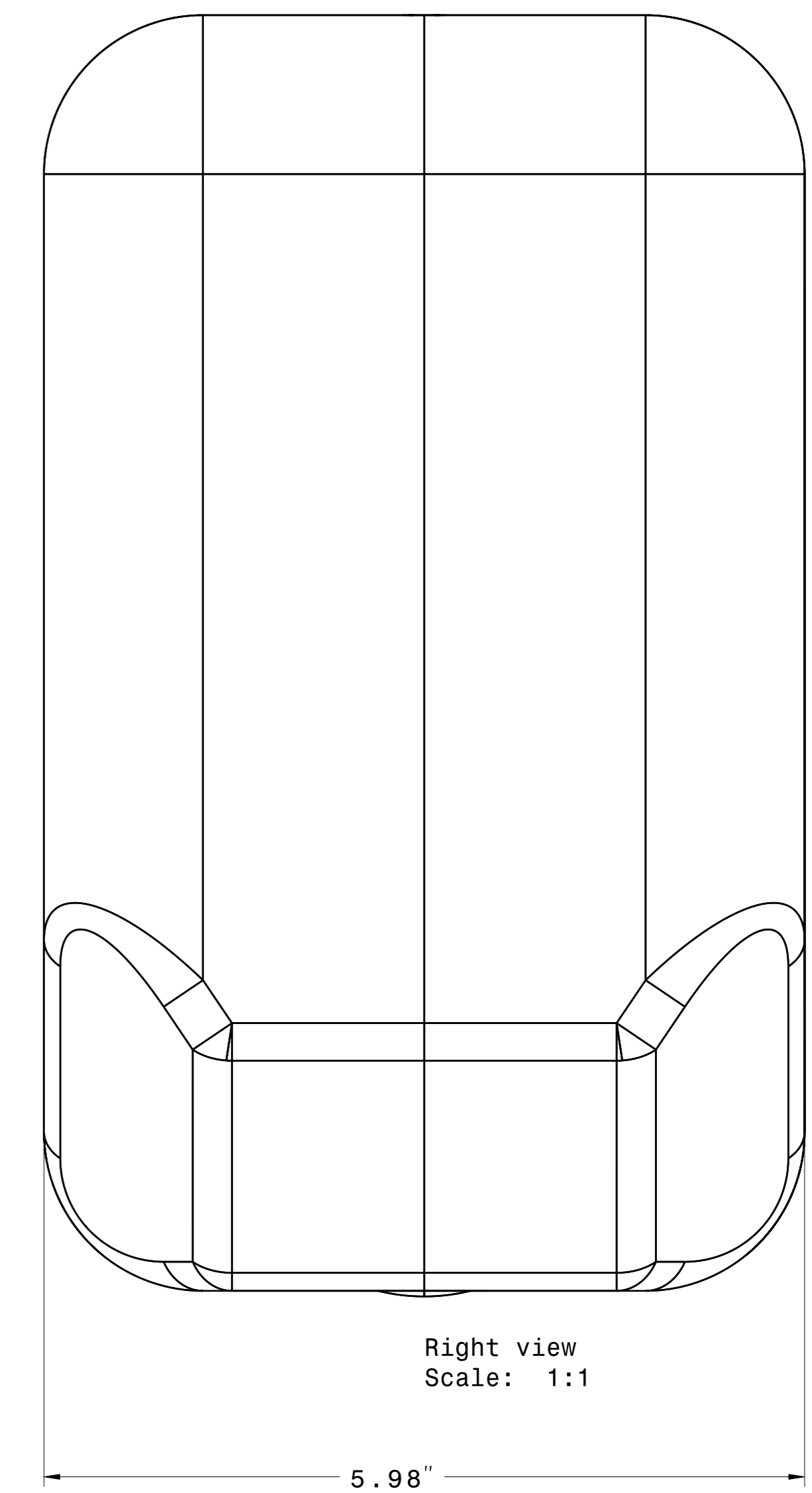

Right view
Scale: 1:1

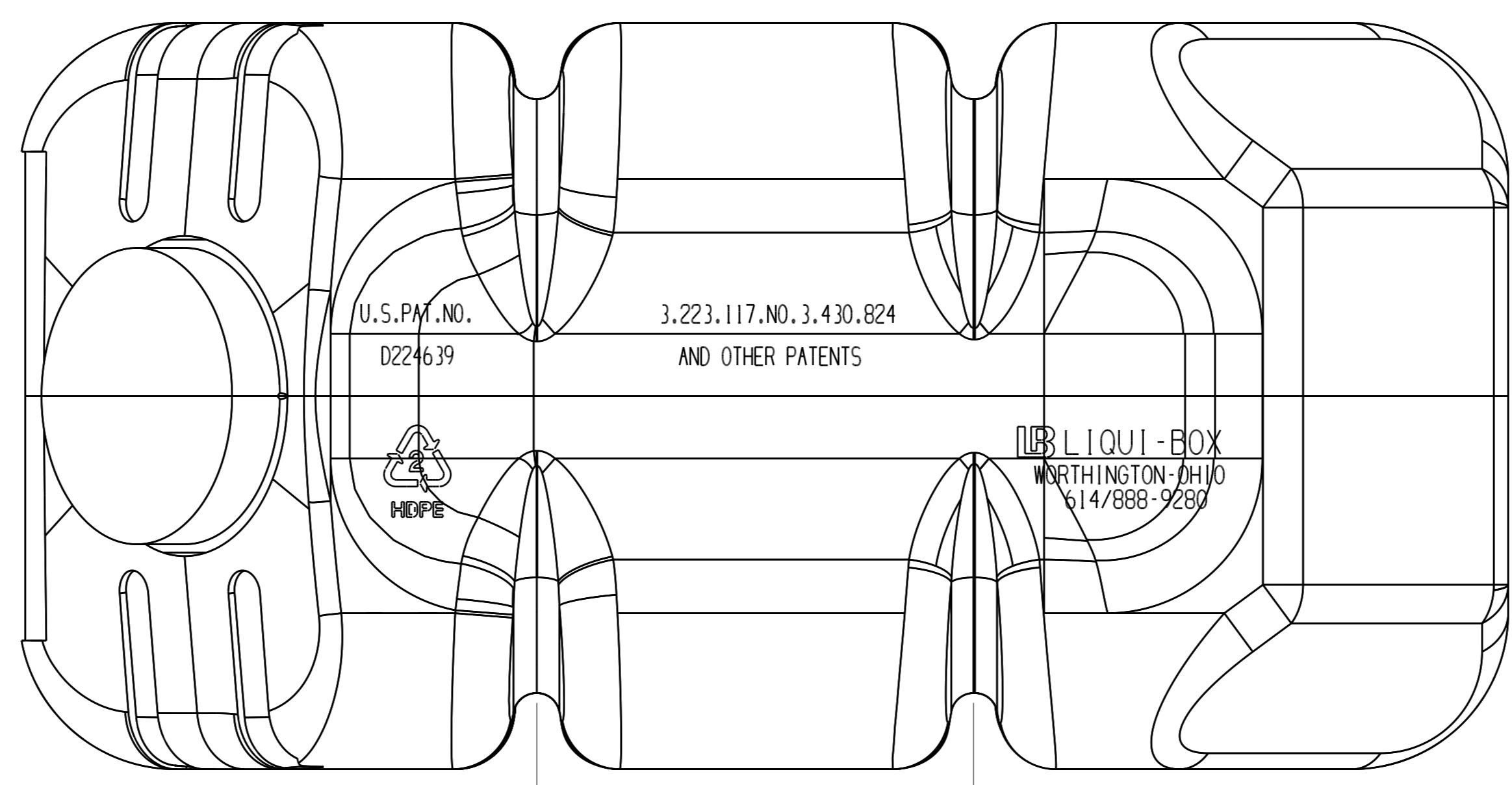

Bottom view
Scale: 1:1

| | | |
|---|-------------|-----------------------------------|
| CAPACITY AT F.P. | ORIGIN | DRAWING |
| OVERFLOW CAP. | O/ BASE | DRAWING |
| BOTTLE WT. | PREFORM | FINISH |
| BASE STYLE | | |
| <small>THIS DRAWING IS THE PROPERTY OF WENTWORTH MOLD INC. AND IS NOT TO BE REPRODUCED OR TRANSMITTED IN ANY FORM OR BY ANY MEANS, ELECTRONIC OR MECHANICAL, INCLUDING PHOTOCOPYING, RECORDING, OR BY ANY INFORMATION STORAGE AND RETRIEVAL SYSTEM, WITHOUT THE WRITTEN PERMISSION OF WENTWORTH MOLD INC.</small> | | |
| <small>There is no warranty, agreement, or representation of condition, expressed, implied, statutory or otherwise, made by Wentworth Mold Inc. in this drawing and the subject matter thereof and the information contained herein is to be used only as a guide in the manufacture of the articles shown.</small> | | |
| <small>UNLESS OTHERWISE SPECIFIED DIMENSIONS ARE IN INCHES GENERAL TOLERANCES ARE</small> | | |
| 3 DECIMALS | ±.001 | |
| 2 DECIMALS | ±.005 | |
| 1 DECIMAL | ±.010 | |
| FRACTIONS | ±.015 | |
| DO NOT SCALE DRAWING | DRAWN J. S. | CHECKED DATE AUG 17, 04 SCALE F/S |

wentworth mold Inc.
best value company

FOR LIQUID-BOX CORPORATION DRAWING NUMBER 110862A SHEET OF MATERIAL: HDPE

2.5 Gallon HANDI-TAP WATER ARTICLE DRAWING RELEASE DATE