

OVERFLOW CAPACITY: 518.5 ± 11 CC

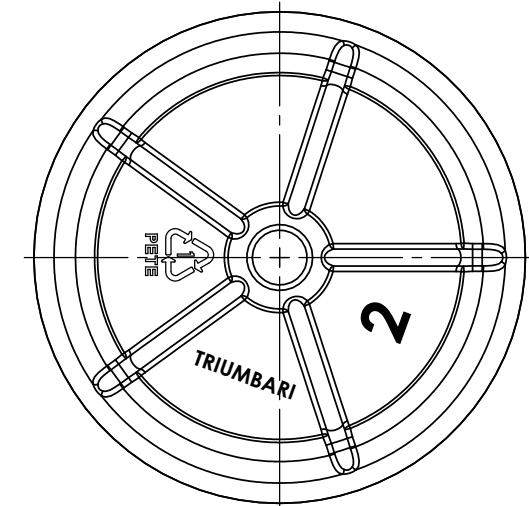

OVERFLOW CAPACITY : 510 ± 11 CC

1. PERFORM WEIGHT : 18gr
2. FILL CAPACITY : 500 ± 11 CC
3. ALL CALCULATION & VOLUMES APPROXIMATE UNTIL FINAL PRODUCTION
4. ALL NOTES APPLIED UNLESS OTHERWISE SPECIFIED

CONFIDENTIAL		MAT'L: PETE	FINISH: 28MM-PCO	
THIS DRAWING AND THE INFORMATION HEREIN ARE CONFIDENTIAL AND NOT TO BE DISCLOSED WITHOUT THE EXPRESS CONSENT OF MOLD-SPEC INC.		DTL BY: M.P.	MOLD-SPEC INC.	
		DATE: JUNE-14-05		
		MD'L BY: M.P.	429 Dewitt Road, Unit 8 Stoney Creek, Ontario, L8E 4C3 E-Mail: engineering@moldspec.com Web Site: www.moldspec.com	
		DATE: JUNE-14-05	Tel: (905) 664-2776 Fax: (905) 664-8163 1-800-251-4596	
TOLERANCES		CUSTOMER: TRIUMBARI	PROD. No.:	-
.X = ±0.010		PRODUCT: 500ml RIBBED ROUND WATER	MACHINE:	-
.XX = ±0.005		TITLE: PRODUCT DRAWING		
.XXX = ±0.001		SCALE: FULL & NOTED	JOB No.:	MS-3433
ANGLES = ±30°		SHEET: 1 OF 1	DWG No.:	C-3433-00
ALL DIMENSION ARE AT MMC UNLESS OTHERWISE SPECIFIED		REV.:		

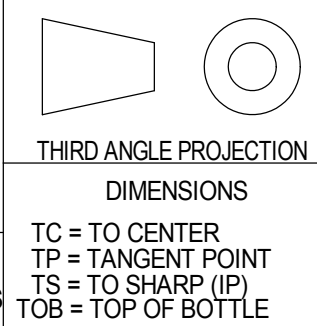

CAD SOLIDWORKS